

# INCREASING ACCESS TO SECONDARY SCHOOL LEVEL EDUCATION THROUGH THE PRODUCTION OF QUALITY LEARNING MATERIALS

---

**JUNIOR SECONDARY LEVEL**

# PHYSICS

## Module 5: Magnetism and Electricity

---

**Partners:**

Ministry of Education and Botswana College of Distance and Open Learning (BOCODOL), Botswana

Ministry of Education, Science and Technology and the Malawi College of Distance Education (MCDE), Malawi

Ministry of Education, Mozambique

Ministry of Basic Education, Sport and Culture, and the Namibian College of Open Learning (NAMCOL), Namibia

Ministry of Education and the Emlalatini Development Centre, Swaziland

Ministry of Education and Culture and the Institute of Adult Education, Tanzania

Ministry of Education, Zambia

Ministry of Education, Sport and Culture, Zimbabwe

Commonwealth of Learning



COMMONWEALTH *of* LEARNING



## CONTRIBUTORS TO PROJECT - PHYSICS

Course Writer

D. Puchooa

Course Reviewer, Coordinator & Instructional  
Systems Designer

I. Jheengut

Editor

C. Sooben

Text Entry

Mrs. S. Deenanath

Mrs. P. Hurgobin

Mrs. S. Chengalanee

Graphic Artist

F. Bredel

Lay-out and Formatting

Mrs. M. A. Frivole

Science Course Materials Management

Mauritius College of the Air

## REVIEW TEAM

Botswana College of Distance and Open Learning

Lawrence Tshipana

Malawi College of Distance Education

Chris F. Layamaman

Namibian College of Open Learning

Joseph Amon

Institute of Adult Education, Tanzania

Andrew Dominick Swai

Emlaladini Development Centre, Swaziland

Simon Sipho Maseko

NDOLA Institute for Skills Training, Zambia

Christopher Chiluband

Ministry of Education, Sport and Culture, Zimbabwe

Luwis Hlombe

## PILOTING TUTORS

Botswana College of Distance and Open Learning

Thandie Keetsaletse

Namibian College of Open Learning

Jona Mushelenga

Sifundzain High School, Swaziland

Saide Richards

Kibasila Secondary School, Tanzania (Ministry of Education)

John Anania

Nilrumah Teacher's College, Zambia

F. Mubanga

NDOLA Institute for Skills Training, Zambia

Christopher Chiluband

Ministry of Education, Sport and Culture, Zimbabwe

Luwis Hlombe



# **JUNIOR SECONDARY LEVEL SCIENCE - PHYSICS**

**MODULE 1 – Measurement**

**MODULE 2 – Matter**

**MODULE 3 – Energy**

**MODULE 4 – Sound, Waves and Light**



**MODULE 5 – Magnetism and Electricity**



## TABLE OF CONTENTS

INTRODUCTION.....	3
OBJECTIVES.....	3
5.1 ABOUT MAGNETS .....	4
5.1.1 POLES OF A MAGNET .....	6
5.1.2 LINES OF FORCE.....	9
5.1.3 MAGNETIC FIELD PATTERN OF A BAR MAGNET .....	11
5.1.4 USING A COMPASS NEEDLE .....	12
5.2 STATIC ELECTRICITY .....	14
5.2.1 LAW OF ELECTROSTATICS .....	15
5.2.2 LIGHTENING AND THUNDERSTORM .....	15
5.3 ELECTRIC CURRENT .....	16
5.3.1 ELECTRIC CHARGE .....	17
5.3.2 VOLTAGE OR POTENTIAL DIFFERENCE .....	17
5.4 RESISTANCE .....	18
5.4.1 SERIES ARRANGEMENT.....	18
5.4.2 PARALLEL ARRANGEMENT OF RESISTANCES .....	19
5.5 EFFECTS OF AN ELECTRIC CURRENT.....	21
5.6 MAGNETIC INDUCTION .....	25
5.6.1 MAGNETIC PROPERTIES OF IRON AND STEEL .....	26
5.6.2 AN ELECTROMAGNET.....	28
5.7 AN ELECTRIC MOTOR .....	31
5.8 THE ELECTRIC GENERATOR.....	32
5.9 USE OF ELECTRICITY IN THE HOME – MAINS ELECTRICITY .....	33
5.9.1 THE DOMESTIC WIRING SYSTEM .....	33
5.9.2 OTHER FEATURES OF THE DOMESTIC WIRING SYSTEM.....	34
5.9.3 SAFE USE OF ELECTRICITY IN THE HOME.....	35
5.10 CONSERVATION OF ELECTRIC ENERGY.....	40
5.10.1 WORKING OF A SIMPLE LIGHT BULB .....	40
5.11 ELECTRICAL POWER .....	41
POINTS TO REMEMBER .....	45
ANSWERS TO ACTIVITIES .....	47



# MODULE 5

---

## MAGNETISM AND ELECTRICITY

---

### INTRODUCTION

This is the last Module of the physics component of this programme. It is about magnetism and electricity. You will first learn about magnets, their properties and their applications in various devices. Then we introduce you to a very practical area namely electricity, including the safe use of electrical energy in the home.

### OBJECTIVES

After completing this Module you should be able to

- state the properties of magnets
- distinguish between temporary and permanent magnets
- explain the working of an electromagnet
- list some uses of electromagnets
- describe how electricity can be generated
- distinguish between direct and alternating currents
- discuss ways of making use of electricity in the home safer
- perform simple calculations on electrical power

## 5.1 ABOUT MAGNETS

I am sure you must have played with magnets at one time or another. Magnets contain oxides of iron. Magnets appear quite strange at first. They attract certain objects, for example, an iron nail or a pin made of steel. This implies a magnetic force. The iron nail and the pin are said to be magnetic. On the other hand, if you bring a magnet near a piece of copper wire, wood or plastic, these are not attracted. They are non-magnetic.

 *Before proceeding further, complete the following activity.*

<b><u>Activity 1</u></b>	
<i>Give four examples of</i>	
<i>(i) magnetic materials</i>	
<i>(ii) non-magnetic materials</i>	
(i) Magnetic Materials	(ii) Non Magnetic Materials

*You will find the answers at the end of the Module.*



**5.1.1 POLES OF A MAGNET**

A magnet normally has two poles - the north pole and the south pole.

 *Before proceeding further, complete the following activity.*

**Activity 2**

(a) *In a bar magnet, its power to attract magnetic materials appears to be concentrated in regions near the ends of the magnet.*

*How are the regions called?*

.....

(b) *Name the materials of which magnets are made.*

.....

***You will find the answers at the end of the Module.***





You must have observed that:

- (i) a North Pole repels another North Pole.
- (ii) a South Pole repels another South Pole.
- (iii) a North Pole attracts a South Pole.
- (iv) a South Pole attracts a North Pole.

Thus we can generalise that **LIKE POLES REPEL UNLIKE POLES ATTRACT**.

This statement is referred to as the 'Law of Magnetic Poles'.

### 5.1.2 LINES OF FORCE

We have just seen that like poles repel and unlike poles attract.

Now let us consider a 'free' or 'isolated' north pole (Z). If it were placed near the N Pole of a bar magnet it would be repelled by the N of the magnet and attracted by the S of the magnet. The path that Z would follow is called a line of force or a magnetic line of force. See diagram below:

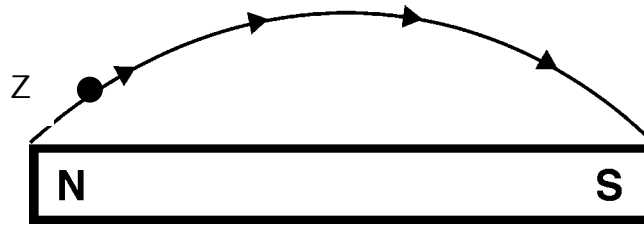

This can be repeated using slightly different positions of Z near the north pole.

You will note a pattern is formed. This pattern of magnetic lines of force is called magnetic field. It is important to remember that a magnetic line of force has a direction - given by the direction of the arrow.

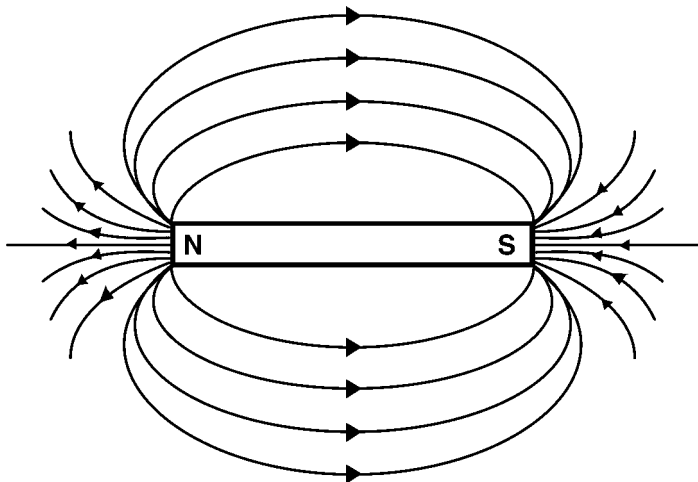

***✍ Before proceeding further, complete the following activity.***

**Activity 3**

**Lines of force around a magnet**

*Consider each of the five statements below. Write TRUE or FALSE as appropriate.*

1. *A magnetic line of force starts at a N Pole and ends at a S Pole.*  
.....
2. *A collection of lines of force associated with a magnet constitute its magnetic field.*  
.....
3. *A magnetic field has a pattern of lines of force.*  
.....
4. *In a magnetic field, the lines of force always cross one another.*  
.....
5. *Magnetic lines of force have no direction.*  
.....

***You will find the answers at the end of the Module.***



I am sure you noticed that the iron filings form a pattern about the magnet. The pattern gives the magnetic field of the magnet. See diagram below.

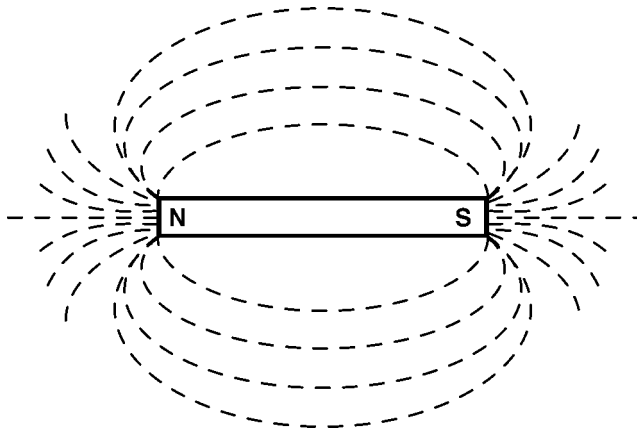

#### 5.1.4 USING A COMPASS NEEDLE

A compass needle is often used to plot the magnetic lines of force and hence the magnetic field pattern of a magnet. Let's see how this is done.

The magnet is placed on a sheet of paper (on the table).

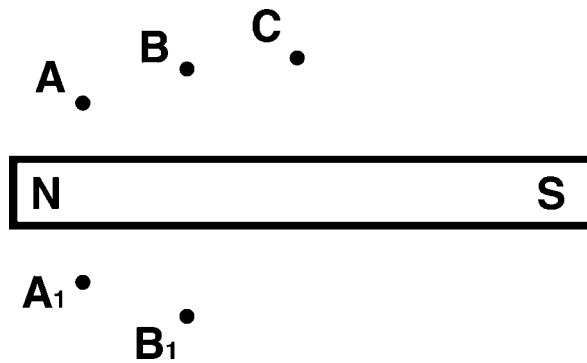

A compass needle is placed relative to position A as shown. The head of the needle is marked B. The compass needle is moved to B so that the tail is now pointing towards B. The head is marked as C. We continue in this manner.

We repeat on the other side at positions  $A_1$ ,  $B_1$  etc.

We join up each set of points. This will give the following pattern.

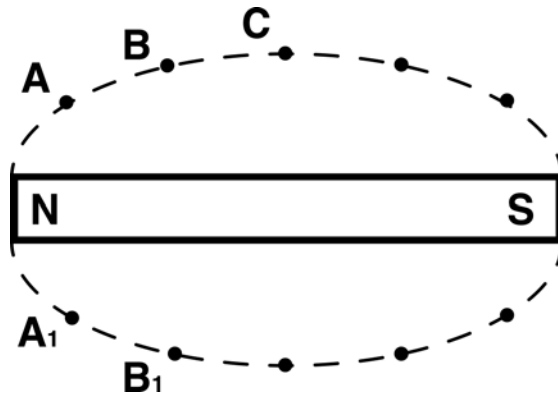

***✍** Before proceeding further, complete the following activity.*

#### Activity 4

##### *The Compass Needle*

*Read carefully each statement below. Insert True or False as appropriate*

- (a) *The compass needle has a very light magnet pivoted horizontally*
- (b) *When no magnets occur near a compass needle, its light magnet points in the north-south direction.*
- (c) *We cannot use a compass needle to find out the pattern of lines of force in a magnetic field.*
- (d) *When a compass needle is placed near a magnet, it shows a deflection.*
- (e) *The compass needle is used in ships and airplanes to indicate direction.*

**You will find the answers at the end of the Module.**



You must have noted that the small pieces of paper are attracted by the polythene strip. This can be explained as follows:

When the polythene rod is rubbed with the soft cloth, some electrons from the soft cloth are transferred to the polythene strip.

The polythene strip has thus an excess of electrons and hence a negative charge. The polythene strip has been charged negatively by friction (by rubbing). The negatively charged rod can thus attract small pieces of paper.

Similarly when a glass rod is rubbed with silk, some electrons are transferred from glass to silk. The glass thus gets positively charged by friction.

### 5.2.1 LAW OF ELECTROSTATICS

According to this law,

Like charges always repel

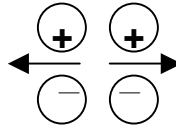

Unlike charges always attract

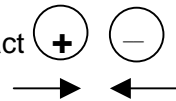

### 5.2.2 LIGHTENING AND THUNDERSTORM

Have you ever seen flashes of lightening? It normally occurs just before or during a thunderstorm.

Lightening is a natural phenomenon. In fact electric charge often builds up in the clouds as a result of friction from winds. When the charge is sufficiently big, the molecules in the air are said to be 'ionised'. Under these circumstances the big charge flows from the cloud to the earth as lightening. We often refer to lightening as a natural discharge between clouds and the earth.

## 5.3 ELECTRIC CURRENT

### What is an electric current?

An electric current can be regarded as a flow of charge. It is measured in Amperes (A) by an instrument called an ammeter. We shall denote an electric current by 'I'.

We can obtain an electric current from a dry cell (for example the one used in a torch). A torch uses dry cells. These dry cells provide an electric current which lights the bulb. The current provided by these cells is referred to as a direct current (d.c). It always flows in one direction from the positive terminal to the negative terminal. An arrangement of cells as shown is referred to as a battery.

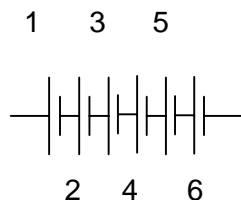

**A battery of six cells**

Thus cells and batteries provide direct current. Please note that the symbol for one cell is

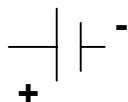

In your house, the electric current you use for lighting or heating is different. This electricity is referred to as 'Mains' electricity - which provides an electric current whose direction is not constant as in the case of a direct current. In fact the current provided by the mains changes its direction many times in a second. In other words the direction 'alternates'. This current is called an alternative current (a.c.)

### 5.3.1 ELECTRIC CHARGE

Electric charge is measured in Coulombs. It is calculated as:

$$\begin{array}{rcl} \text{Charge} & & \text{Current} & & \text{Time} \\ \text{in} & = & \text{in} & \times & \text{in} \\ \text{Coulombs} & & \text{amperes} & & \text{seconds} \end{array}$$

### 5.3.2 VOLTAGE OR POTENTIAL DIFFERENCE

The voltage or potential difference is measured in Volts. The potential difference between 2 points A and B in volts means the work done in joules to transfer a charge of 1 coulomb from A to B.

Consider the following example where the potential difference between P and Q is 12 volts.

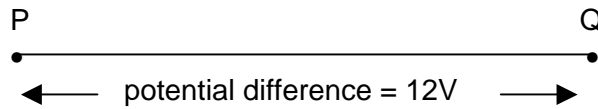

This means 12J of work is done to transfer a charge of 1 coulomb from P to Q.

 *Before proceeding further, complete the following activity.*

#### **Activity 5**

*The potential difference between P and Q is 10 volts. How much work is done to transfer 5 coulombs of charge from P to Q*

***You will find the answer at the end of the Module.***

## 5.4 RESISTANCE

The resistance of a conductor refers to its ability to resist the flow of charge. Resistance is measured in Ohms ( $\Omega$ ). It is denoted by R and its

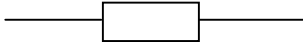
symbol is  or 

Resistances can be combined in :

- (i) Series (that is one after another)
- (ii) Parallel

### 5.4.1 SERIES ARRANGEMENT

When two resistances  $R_1 \Omega$  and  $R_2 \Omega$  are connected in series,

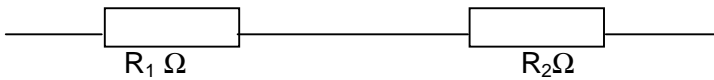

The combined resistance,  $R = (R_1 + R_2) \Omega$

 *Before proceeding further, complete the following activity.*

**Activity 6**

What is combined resistance in each case?

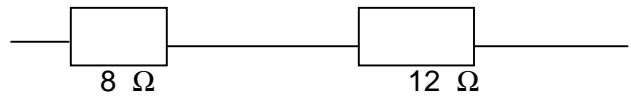
(i) 

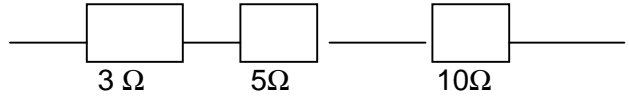
(ii) 

*You will find the answers at the end of the Module.*

### 5.4.2 PARALLEL ARRANGEMENT OF RESISTANCES

When 2 resistances  $R_1$ , and  $R_2$  are arranged in parallel, the combined resistance  $R$  is given by

$$\frac{1}{R} = \frac{1}{R_1} + \frac{1}{R_2}$$

 Before proceeding further, complete the following activity.

**Activity 7**

What is the combined resistance in each case?

(i)

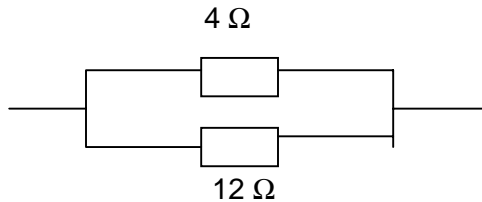

(ii)

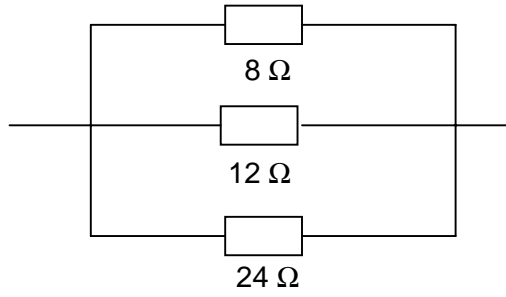

**You will find the answers at the end of the Module.**

So far we have explained the meaning of

- electric current (I)
- potential difference (V)
- resistance (R)

At this stage, it is useful to know that these three quantities are related by the formula

$$V = IR$$

In fact the expression

$$V = IR$$

Is known as Ohm's law. This relationship was established by the German physicist G.S.Ohm.

You will find this expression useful in simple calculations.

 *Before proceeding further, complete the following activity.*

### Activity 8

A current of 3A passes through a resistance of 6  $\Omega$  as shown. What is

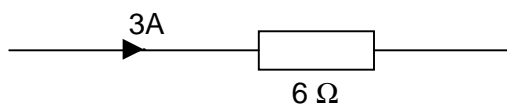

the potential difference across the 6  $\Omega$ ?

***You will find the answers at the end of the Module.***



	<p><i>Record your observations</i></p> <p>.....</p> <p>.....</p> <p>.....</p> <p>.....</p> <p>.....</p>
--	---

I am sure that in (a) you noticed the compass needle showing a deflection.

In (b) the deflection is cancelled.

In (c) the final observation should be a circular pattern around the wire. This pattern is the magnetic field pattern due to a current flowing through a wire.

We have just learnt that an electric current gives rise to a magnetic field. Thus an electric current has a **magnetic effect**.

A similar effect is observed when an electric current flows through a **solenoid**. A solenoid is just a coil of several turns of insulated copper wire. The following pattern illustrates the magnetic field set up as the electric current flows through the solenoid.

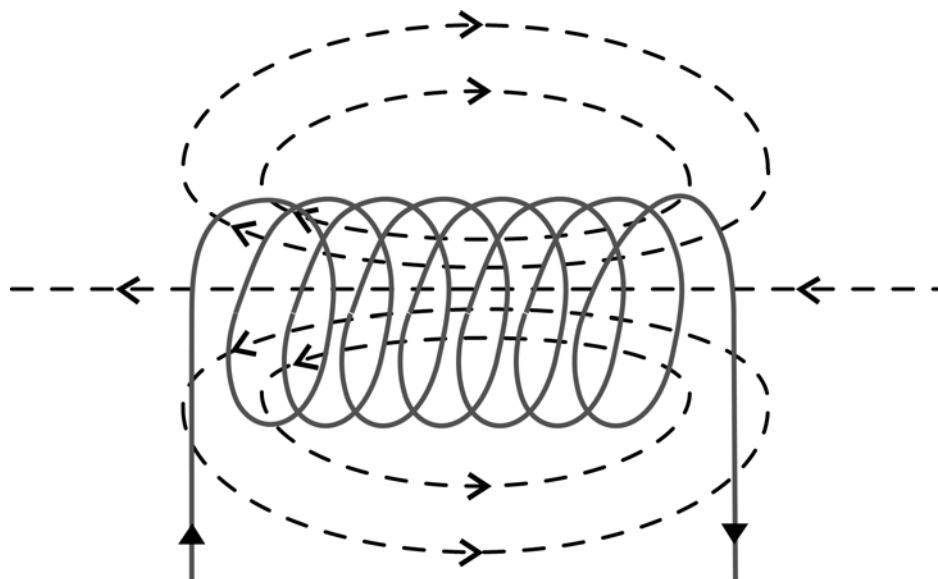

 *Before proceeding further, complete the following activity.*

**Activity 9**

*An insulated copper wire is made into a number of turns (called a solenoid). If this were connected to a battery, the solenoid would carry a current. Sketch the solenoid and draw the magnetic field.*

*Do not forget to include*

- (i) direction of current*
- (ii) direction of lines of force in the resulting magnetic field*

***You will find the answer at the end of the Module.***

So far we have considered the magnetic effect of an electric current. Apart from a magnetic effect, an electric current also has a **heating effect**.

- When an electric current passes through a wire, the wire becomes hot. Heat is produced. Electrical energy is converted into heat.
- When we use an electric iron, an electric current flows through the heating element. Electrical energy is converted into heat.
- Similarly when we put on a kettle full of water, electrical energy is changed into heat energy.
- In winter, when we put on the electric heater, electrical energy is converted into heat energy.

There are many other such examples that illustrate that electrical energy can be converted into heat energy.

 *Before proceeding further, complete the following activity.*

### **Activity 10**

*We have learnt that electrical energy can be converted into HEAT energy.*

(a) *How is this effect of an electric current called?*

.....

(b) *Give a few examples of the above effect.*

1<sup>st</sup> .....

2<sup>nd</sup> .....

3<sup>rd</sup> .....

4<sup>th</sup> .....

(c) *How does it arise?*

.....

***You will find the answers at the end of the Module.***

## 5.6 MAGNETIC INDUCTION

When a pin made of iron or steel is brought near the pole of a magnet, it is attracted to the magnet. It itself becomes a magnet. We say that the pin has induced magnetism. The process of inducing magnetism in the pin is called magnetic induction. Instead of a pin, we can use a soft-iron bar, AB.



The end A is attracted. A north pole is induced at A and a south pole at B. Thus the soft iron becomes an induced magnet. It can in turn attract other magnetic materials such as a pin made of iron or steel.

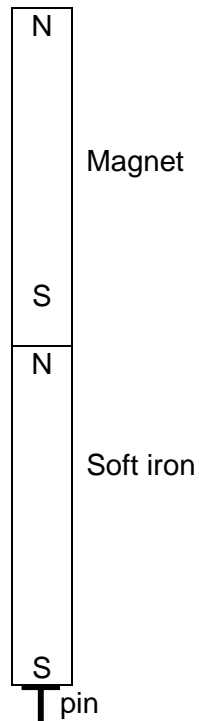

### 5.6.1 MAGNETIC PROPERTIES OF IRON AND STEEL

Although steel contains iron, its magnetic properties are quite different from iron. We shall refer to our earlier knowledge on induced magnetism to illustrate this. We can use steel pen nibs and iron paper clips together with a magnet. The pen nibs and paper clips are brought near the magnet. One of each is added successively as shown. The successive pen nibs and paper clips are attracted by induced magnetism. A stage is reached when the pen nibs and the paper clips are no longer attracted. The induced magnetism is too weak. The diagram below illustrates this situation.

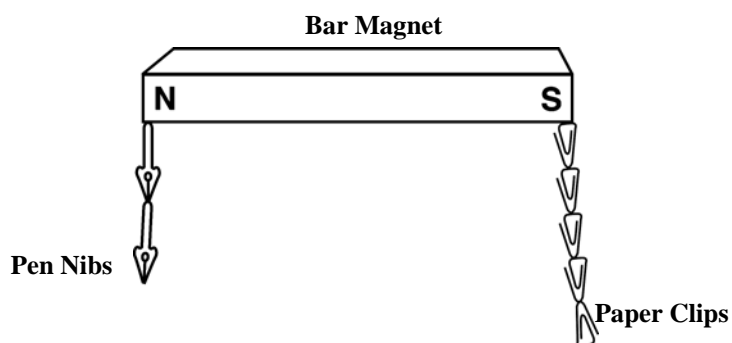

*What do you deduce?*

This simple experiment shows that the iron paper clips are more easily magnetised than the steel nibs.

Now if we just detach the first paper clip from the magnet, all the other paper clips fall down.

On the other hand if we detach the first steel nib from the magnet, the other nibs do not fall down.

*What do you deduce?*

Steel nibs retain the magnetism but iron paper clips do not. The magnetism induced on the iron is temporary while that on the steel nibs is permanent.



The iron pins are magnetised more easily than those of steel.

### 5.6.2 AN ELECTROMAGNET

You will recall that iron is easily magnetised and iron can be used for making temporary magnets. Moreover we learnt that an electric current has a magnetic effect.

We can now look at how a direct electric current passing through a coil of copper wire wound on an iron rod can act as a magnet. The iron rod acts as a magnet as long as the current is flowing. This can be illustrated using the diagram below.

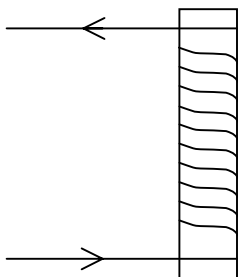

If the current is switched off, the iron is no longer a magnet. Such a magnet is called an electromagnet.

You realise that it is quite easy and simple to make an electromagnet. The following investigation will make it clearer.



## Uses of electromagnets

There are numerous uses of electromagnets. In some cases they are used for lifting large quantities of magnetic materials and transferring them to another place. Another application is in the electric bell. A telephone earpiece also contains an electromagnet. Thus electromagnets are useful components of a number of devices.

Can you think of other examples?

 *Before proceeding further, complete the following activity.*

### Activity 11

#### Magnetic properties of iron and steel

For **each** of the following, select between **iron** and **steel**

- (a) *Is easy to be magnetised.*  
.....
- (b) *Once it is magnetised, it loses its magnetism easily.*  
.....
- (c) *Is difficult to be magnetised.*  
.....
- (d) *Once it is magnetised, it retains its magnetism i.e. does not lose it easily.*  
.....
- (e) *Is suitable as material for permanent magnets.*  
.....
- (f) *Is good as material for temporary magnets.*  
.....
- (g) *Is suitable for use as an electromagnet (this is magnetised when an electric current flows in a solenoid around it; but the moment the current is switched off, it loses its magnetism.*  
.....

***You will find the answers at the end of the Module.***

## 5.7 AN ELECTRIC MOTOR

An electric motor is an important component of many electric devices we use in the home. These include electric mixers, washing machines and vacuum cleaners. Other examples include electric trains and lifts. Even in the car the working of the windscreen wipers depends upon an electric motor. The working of all the above devices is governed by the “**motor effect**”.

“A wire carrying an electric current in a magnetic field experiences a force. If the wire is free to move then the wire moves.”

In all electric motors, an electric current flows through a coil that is situated in a magnetic field. The coil rotates as a current flows.

 *Before proceeding further, complete the following activity.*

### Activity 12

#### The Electric Motor

(a) *What is an electric motor?*

.....  
.....

(b) *How can a simple electric motor be made? Illustrate with a sketch.*

***You will find the answers at the end of the Module.***

## 5.8 THE ELECTRIC GENERATOR

In an electric motor, we apply an electric current in a coil situated in a magnetic field to obtain mechanical energy (due to rotation of coil). The electric generator does the reverse – i.e. we rotate a coil in a magnetic field to generate an electric current.

 *Before proceeding further, complete the following activity.*

### Activity 13

- (a) *Show the alterations which have to be made to the model electric motor (in activity 12) in order to convert it into a simple generator.*
- (b) *How is electricity generated using a dynamo?*

***You will find the answers at the end of the Module.***

## 5.9 USE OF ELECTRICITY IN THE HOME – MAINS ELECTRICITY

You will recall that we mentioned earlier in this Module that electricity in our homes comes from the 'MAINS' – as alternating current. Let's now look at the safe use of electricity in the home.

### 5.9.1 THE DOMESTIC WIRING SYSTEM

The electricity comes to our homes through cables. In our home the wiring system has three wires. These are:

- (i) The live (L) wire
- (ii) The neutral (N) wire
- (iii) The earth wire (E) wire

#### **The Live wire**

The live wire is at high voltage (about 240V) and hence dangerous.

It is brown in colour. Previously it was red.

#### **The neutral wire**

The neutral wire is at zero volt. It is coloured blue. Previously it was black

#### **The earth wire**

The earth wire is in fact a safety device. This is important especially for an electric appliance having a metal frame or metal stand. It helps to avoid electric shocks in case there is a fault or the live wire touches the casing of the appliance. It is coloured yellow with green strips or green with yellow strips.

### 5.9.2 OTHER FEATURES OF THE DOMESTIC WIRING SYSTEM

A careful study of the domestic wiring system reveals the following features:

- switches
- fuses

#### **A switch**

A switch is a device that helps to make or break the circuit. Thus you can use it to put an appliance on or off. It is useful to remember that all switches are placed in the live wire – the brown one. This ensures that the appliance is not connected to the live wire when the switch is in the “off” position.

#### **A fuse**

A fuse is a safety device that controls the maximum safe current flowing in a circuit. If the current exceeds the maximum safe value, the fuse wire gets overheated and melts. Thus it breaks the circuit. Fuses are always placed in the live wire. This ensures that the appliance will not become live after the fuse has blown or melted.

It is also important to choose the fuse properly. The rating of the fuse must be such that it is just above the normal current flowing in the circuit - for example if a circuit takes a current of 11 A, then a suitable fuse rating will be 13A.

Other features include fused plugs and circuit breakers. Some appliances such as vacuum cleaners, hairdryers and food mixers have double insulation. The appliance is enclosed in a plastic case.

 Before proceeding further, complete the following activity.

**Activity 14**

(a) Explain

(i) direct current

.....

(ii) alternating current

.....

(b) Explain carefully why it is important to place all switches and fuses in the live wire and not in the neutral wire

.....

.....

.....

**You will find the answers at the end of the Module.**

### 5.9.3 SAFE USE OF ELECTRICITY IN THE HOME

In the last 2 decades there has been an increase in the use of electric domestic appliances. These include:

- electric irons
- heaters
- air conditioners
- ovens
- washing machines
- cookers

There are many more! You may also may think of computers, printers, drilling machines, and lawn mowers.

 *Before proceeding further, complete the following activity.*

### **Activity 15**

*Name some domestic appliances which make use of electric energy.*

*(a) In the kitchen*

.....  
.....

*(b) In other places in the home*

.....  
.....

***You will find the answers at the end of the Module.***

The increase in the use of an increasing number of appliance may increase the risks of accidents unless we are aware of the dangers and safety precautions are taken. This is what we see discuss in the next section.

### **Safety precautions**

Inadequate knowledge of electricity and the associated features can be dangerous.

Let's recapitulate the important features we have considered so far. You will recall:

- (i) all fuses and switches must be placed in the live wire
- (ii) all appliances with a metal part must be earthed
- (iii) circuit breakers are important

- (iv) fuses should have a rating that is just above the normal current taken by the circuit.

In addition to the above, electrical faults often develop in appliances or circuits. These can cause fire, electric shocks or even electrocution to users. The dangers may be due to one or more of the following:

- damaged insulation
- overheating of cables
- damp conditions

### **Damaged insulation**

You will recall there are 3 wires (L, N and E) in our domestic wiring system. The two wires that complete the circuit from the electricity supply to the appliance and back to the supply are the Neutral and the Live wires. They are insulated from one another by rubber or plastic. These insulating materials often deteriorate with time. The insulation often gets worn out. The result is that the live wire may become exposed which can in turn lead to electric shock.

### **Overheating of cables**

Overheating of cables can occur if an excessive current flows. This can occur when insulation of the L and N wires are worn out and they touch each other. A '**short circuit**' is then said to occur. A big current flows producing a large amount of heat. This can melt the wire or even start a fire.

### **Damp conditions**

Damp conditions often lead to serious accidents. It is dangerous to change a light bulb with wet hands or put on a switch with wet hands. An electric current can flow more easily through the hand when it is wet.

At this stage, you will find it useful to carry out an investigation. It is about the dangers associated with electricity.

**INVESTIGATION 9: Dangers associated with electricity**

<p><b>You should record your answers in the space provided.</b></p>	<p><b>Method:</b></p> <p><i>Make a survey, in a few homes, concerning dangers to which users of electric energy are exposed.</i></p>
---	--

I am sure you found out one or more of the following:

- At connections of wires, the insulation may show signs of being damaged.
- Overheating of certain electric devices e.g. the electric iron or electric shower.
- Damp plugs/sockets.
- Electrical connections getting worn out and not renewed/replaced.
- Sockets are sometimes low and within reach of children. While playing they may insert metal objects in the sockets and get electric shocks.
- Lack of earthing in the case of an electric oven, refrigerator etc.

 Before proceeding further, complete the following activity.

**Activity 16**

Consider each statement below. Think well over each one and put a tick or a cross.

- Suitable fuses serve to control the current flowing in a circuit
1. The circuit breaker is a safety device that functions automatically.
2. The circuit breaker switches off the main current in the home when a serious fault occurs in electric connections/devices in the home.
3. Double insulation provides greater safety than single insulation.
4. Earthing is a safety measure for a night lamp.
5. Earthing is a safety measure for a refrigerator with a metal frame.

**You will find the answers at the end of the Module.**

## 5.10 CONSERVATION OF ELECTRIC ENERGY

Most of our energy sources are limited, for example, petroleum reserves are being gradually depleted. The cost of electric energy is increasing. Our monthly electricity bill is quite high. There is an urgent need to avoid wastage of electric energy and reduce our electricity bills!

 *Before proceeding further, complete the following activity.*

### Activity 17

(a) *Why should electric energy NOT be wasted?*

.....  
.....  
.....  
.....

(b) *Make a list of the ways in which wastage of electric energy is avoided.*

.....  
.....  
.....  
.....

***You will find the answers at the end of the Module.***

### 5.10.1 WORKING OF A SIMPLE LIGHT BULB

The light bulb is the simplest electric appliance. It's useful to examine how it works. A simple light bulb consists of a coil of thin tungsten wire enclosed in a glass bulb. The glass bulb is filled with an inert gas, argon.

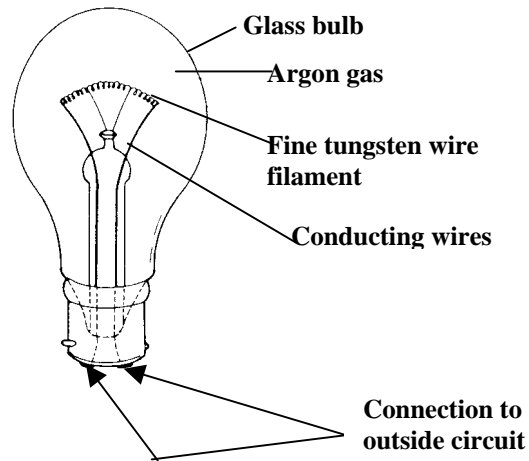

### Connections to lamp

When you switch on the current, the filament becomes very hot (about  $2500^{\circ}\text{C}$ ). At this high temperature, a proportion of the electrical energy is converted into light energy. Some electrical energy is also converted into heat. This is why the bulb becomes warm after a few minutes.

#### *Why is tungsten used for the filament?*

Tungsten is suitable for the filament because it has a high melting point.

#### *Why is the bulb filled with argon?*

Argon is unreactive. Thus it allows the bulb to operate without 'burning' the tungsten.

## 5.11 ELECTRICAL POWER

The term "power" is not new to us. We came across it in Module 3. We are going to apply it to electricity.

 Before proceeding further, complete the following activity.

**Activity 18**

(a) Define power and state the unit for power

.....  
.....

(b) In motor vehicles small bulbs are often marked “6W12V”.

(i) What does “6W” stand for?

.....  
.....

(ii) What does “12V” represent?

.....  
.....

**You will find the answers at the end of the Module .**

**The watt value of electric bulbs**

We just considered the case of a small bulb marked 6W12V. In the home we have bulbs marked 40W240V or 60W240V etc. It is useful to remember that

$$\text{Power} = \text{Voltage} \times \text{Current}$$

 Before proceeding further, complete the following activity.

**Activity 19**

- (a) An electric heater has a power of 40W. It operates at 240V. What is the current it takes when in normal use?

.....  
.....  
.....

- (b) What is the resistance of the heater?

.....  
.....  
.....

**You will find the answers at the end of the Module.**

 Before proceeding further, complete the following activity.

**Activity 20**

An electric oven has a power of 2 KW. How much heat does it produce in 5 minutes?

.....  
.....  
.....  
.....

**You will find the answer at the end of the Module**

### The Kilowatt hour

At this stage, it is useful to note that the cost of electricity is based on the number of kilowatthour (KWh) used. In fact,

$$\text{Number of KWh} = \text{Number of KW} \times \text{Number of hours}$$

Once we know the number of KWh, we can calculate the cost of energy - using the cost of 1 KWh.

 *Before proceeding further, complete the following activity.*

#### Activity 21

*Bearing in mind that 1 KW = 1000 W and that 1 hr = 3600 sec, how much energy (in Joule) is represented by 1 Kilo Watt hour (symbol KWh)?*

.....  
.....  
.....  
.....

***You will find the answers at the end of the Module.***





## ANSWERS TO ACTIVITIES

### Activity 1

(i) Magnetic	(ii) Non Magnetic
Iron	Wood
Steel	Plastic
Cobalt	Lead
Nickel	Aluminium

### Activity 2

- (a) Poles of the magnet
- (b) Iron  
Steel

### Activity 3

- 1. True
- 2. True
- 3. True
- 4. False
- 5. False

### Activity 4

- (a) True
- (b) True
- (c) False
- (d) True
- (e) True

### Activity 5

$$\begin{aligned}\text{Energy} &= \text{Coulombs} \times \text{volts} \\ &= 5 \times 10 \\ &= 50 \text{ J}\end{aligned}$$

### Activity 6

- (i)  $R = 8 + 12 = 20 \Omega$
- (ii)  $R = 3 + 5 + 10 = 18 \Omega$

**Activity 7**

$$(i) \quad \frac{1}{R} = \frac{1}{4} + \frac{1}{12} = \frac{3+1}{12} = \frac{4}{12}$$

$$\frac{1}{R} = \frac{4}{12} \quad \text{i.e.} \quad \frac{1}{3}$$

$$\therefore R = 3 \Omega$$

$$(ii) \quad \frac{1}{R} = \frac{1}{8} + \frac{1}{12} + \frac{1}{24}$$
$$= \frac{3+2+1}{24} = \frac{6}{24} = \frac{1}{4}$$

$$\therefore R = 4 \Omega$$

**Activity 8**

Using  $V = IR$  and replacing

We have

$$V = 3 \times 6$$
$$= 18 \text{ volts}$$

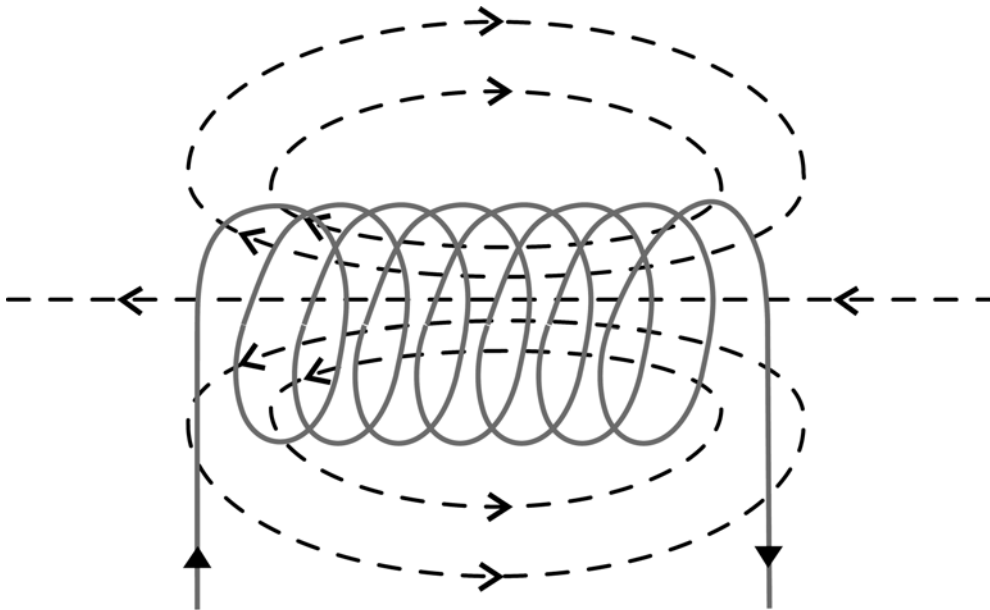
**Activity 9**

**Activity 10**

- (a) The heating effect of an electric current.
- (b)
  - 1<sup>st</sup> Electric iron
  - 2<sup>nd</sup> Electric oven
  - 3<sup>rd</sup> Electric boiler
  - 4<sup>th</sup> Electric grill
- (c) Work done in overcoming electrical resistance is converted into heat.

**Activity 11**

- a. iron
- b. iron
- c. steel
- d. steel
- e. steel
- f. iron
- g. iron

**Activity 12**

- (a) It is a device which converts electrical energy into mechanical energy. In fact, a rectangular coil carries a current. The coil occurs in a magnetic field. The coil rotates about an axis.
- (b)

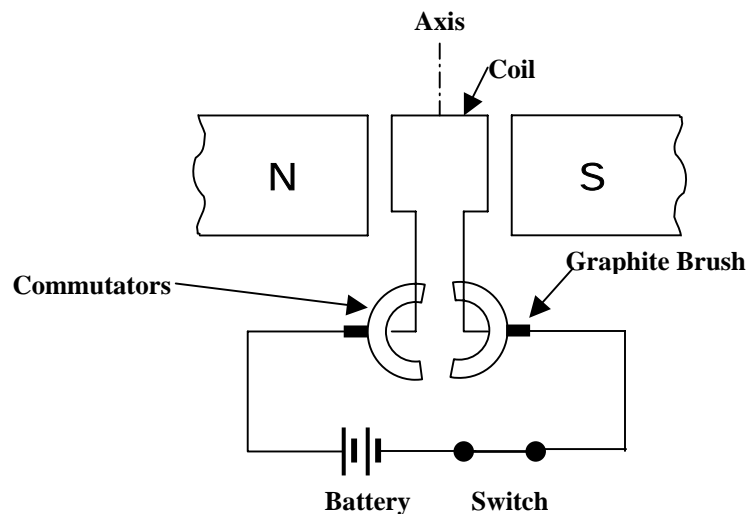

When the current is switched on, the coil rotates about the axis.  
The 2 ends of the coil are connected to 2 half rings or commutators.

**Activity 13**

- (a) The battery is replaced by a lamp. The coil is made to rotate in a magnetic field.  
Mechanical energy is converted into electrical energy. This causes the lamp to light.
- (b) A series of coils are made to rotate rapidly in a magnetic field. Electrical energy is generated.

**Activity 14**

- (a) (i) A current which flows in one direction only.  
(ii) A current which keeps on changing direction.
- (b) In order to 'protect' the electrical device from damage which would result from excessive current.

**Activity 15**

- (a) The refrigerator  
The electric kettle  
The electric grinder/mixer  
The electric grill/oven  
The microwave
- (b) The electric iron  
The hairdryer  
The fan  
The electric brush  
The vacuum cleaner  
The electric bath (water heater)  
The electric bulb/tube  
The door-bell

**Activity 16**

1.
2.
3.
4.
5.
6.

**Activity 17**

- (a) 1. Electric energy is very costly  
2. Most of our energy sources are limited
- (b) 1. Switching off electric lamps/tubes/devices when not required  
2. Using low power electric devices as far as possible  
3. Using gas cooker instead of the electric cooker.

**Activity 18**

- (a) Power is the rate of doing work or of using energy  
The unit of power is the WATT (which is the Joule/Second)
- (b) (i) Each of the bulbs uses energy at the rate of 6 J/S  
(ii) Each such bulb functions at a potential difference of 12 volts.

**Activity 19**

- (a) Power = Voltage x current  
Replacing in the above formula,  
We have:  
40 = 240 x current  
  
Current =  $\frac{40}{240}$  amp =  $\frac{1}{6}$  A
- (b) Voltage = Current x Resistance  
Replacing in the formula, we have:  
240 =  $\frac{1}{6}$  x R  
R = 240 x 6  
= 1440  $\Omega$

**Activity 20**

$$\begin{aligned}
 2 \text{ KW} &= 2000 \text{ W} \\
 5 \text{ mins} &= 5 \times 60 \text{ sec} = 300 \text{ sec} \\
 \text{Heat (Energy)} &= \text{watt} \times \text{sec} \\
 &= 2000 \times 300 \\
 &= 600000 \text{ J} \\
 &\text{or } 600 \text{ KJ}
 \end{aligned}$$

**Activity 21**

$$\begin{aligned}
 1 \text{ KW} &= 1000 \text{ W} \\
 1 \text{ KW used for 1 sec,} &\text{ corresponds to energy of } 1000 \text{ J} \\
 1 \text{ KW used for 3600 sec,} &\text{ corresponds to energy of } 1000 \times 3600 \text{ J} \\
 &= 3600000 \text{ J}
 \end{aligned}$$

